

# **FROM THE EARTH (F.T.E.)**

**Akari Nomiya (Manager of Rocket Project)**

**Yoshinobu Itagaki (Assistant Manager of CanSat Project)**

- Overview of our Team
- Hybrid Rocket Project
- CanSat Project
- Conclusion
- Acknowledgment

## ■ FROM THE EARTH (F.T.E.)

- ✓ Space activity club since 2010
- ✓ Make Hybrid rocket and CanSat
- ✓ Provide space education
- ✓ Number of member: 121



## Our motivation

*“Breakthrough to the atmosphere”*  
*“Dreams and inspiration for all”*

## Our motivation

*“Breakthrough to the atmosphere”*  
*“Dreams and inspiration for all”*



Rocket, CanSat • Education • SNS

## Our motivation

*“Breakthrough to the atmosphere”*

*“Dreams and inspiration for all”*

**Growth as an engineer**

Rocket, CanSat • Education • SNS

# Overview of our Team: Space Education



## FTE members

- How to attract
- Simple explanation
- Contribution to the community



## Participants (Elementary or Junior high school)

- Joy of crafting and space
- Practical experience



PET Bottle Rocket



Model Rocket



Science Workshop

# Annual Schedule



TOHOKU

9	10	11	12	1	2
	School Festival	Space education	Space education	Space education	Space education × 2
Create CanSat				CanSat drop experiment →	
Create Rocket			Combustion Test		
3	4	5	6	7	8
Tanegashima Experiment	Welcome Freshmen	Freshmen Project (model rocket)			
	Space education		Space education	Space education × 3	
Izu Oshima Experiment	Create CanSat			Open Campus	
	Create Rocket	Combustion Test	Combustion Test	Combustion Test	Noshiro Spase Event

Regularly sharing our activities through social media

# Background and Object of Rocket Project

## ■ Background

- ✓ Long-term goal : **Launching High Altitude Hybrid Rocket** × **Releasing a Payload**
- ✓ Mid-term goals : **Reach the altitude of 10 km**, **Release a 3 kg Payload**
- ✓ Procuring commercially available rocket motors → **×**

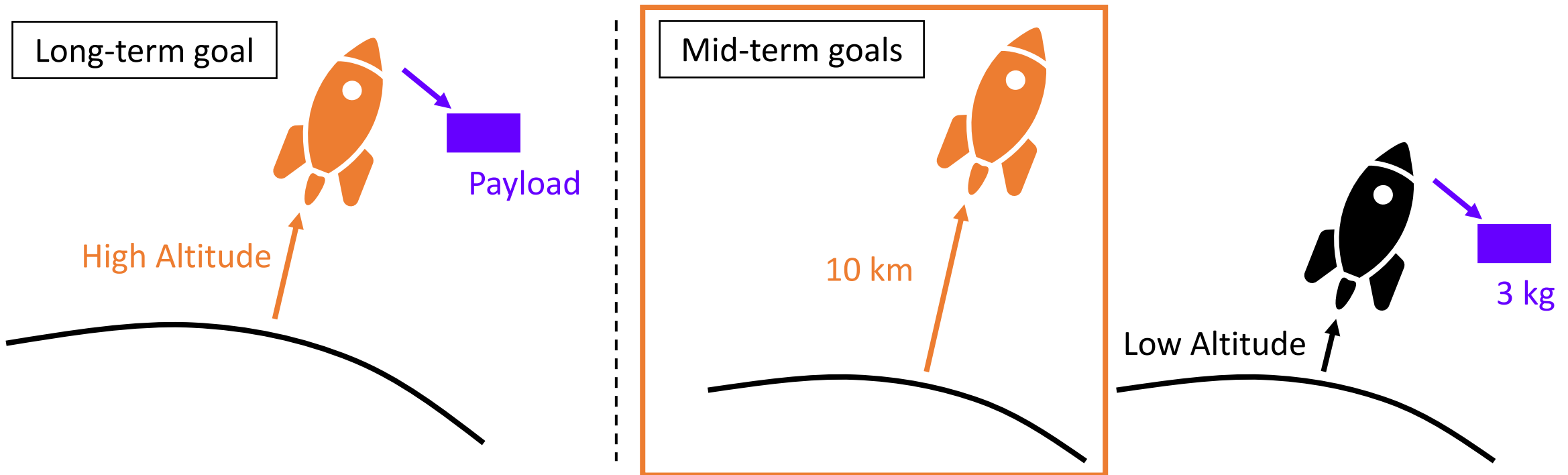

## Objects (Annual Goals)

- ✓ Succession Technology
- ✓ Successful launch a high-altitude sea-launch rocket
- ✓ Establishment of our original hybrid rocket motor



Manufactured 2 rockets



# Activities of Rocket Project

## Objects (Annual Goals)

- ✓ Succession Technology
- ✓ Successful launch a high-altitude sea-launch rocket
- ✓ Establishment of our original hybrid rocket motor

Noshiro Space Event  
(2025/8/13-22)

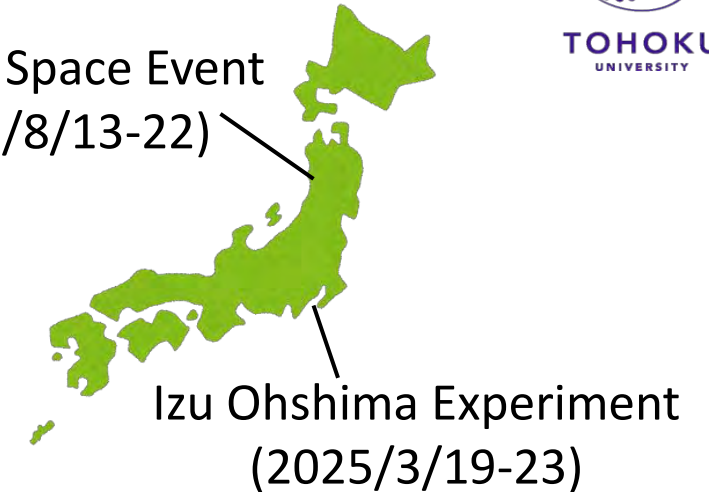

### Spec

- Length : 1728 mm
- weigh : 5.819 kg  
(without propulsion)

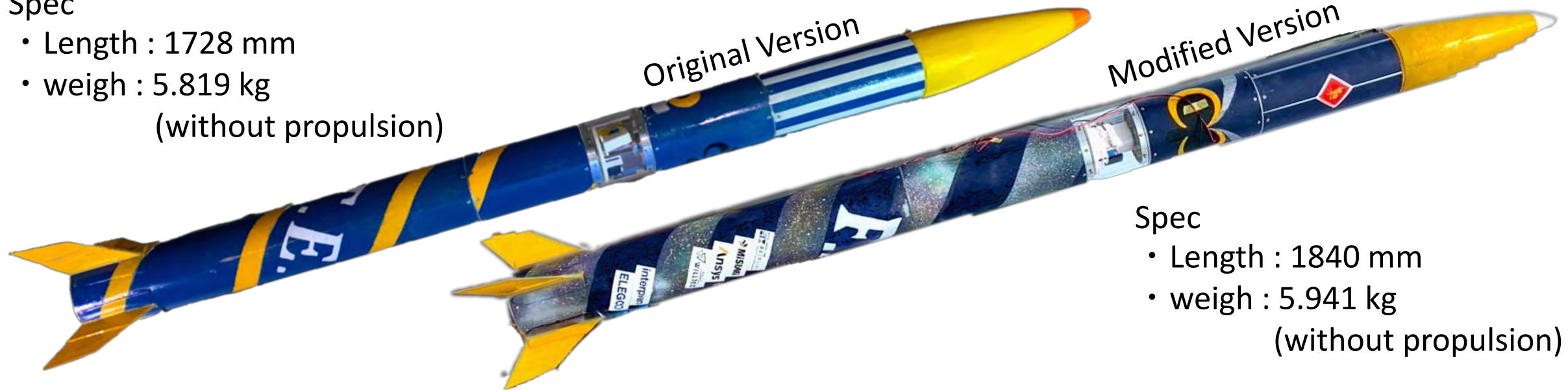

### Spec

- Length : 1840 mm
- weigh : 5.941 kg  
(without propulsion)

# Activities of Rocket Project



Estimated Reaching altitude  
284 m

# Activities of Rocket Project



TOHOKU  
UNIVERSITY



## Objects (Annual Goals)

- ✓ Succession Technology
- ✓ Successful launch a high-altitude sea-launch rocket
- ✓ Establishment of our original hybrid rocket motor

Estimated reaching  
altitude of hybrid rocket  
powered by this motor :  
**2414 m**  
(ideal flight without winds)

## Features

- Material
  - Engine case : Aluminum
  - Nozzle : Graphite
- Propulsion
  - Oxidizer :  $N_2O$
  - Fuel : PMMA
- Total impulse 3250 N·s
- Average impulse : 472 N
- Tank volume : 2000 cc
- Burst Pressure : 6.8 MPa (measured value)
- Maximum combustion pressure : 2.48 MPa (designed value)

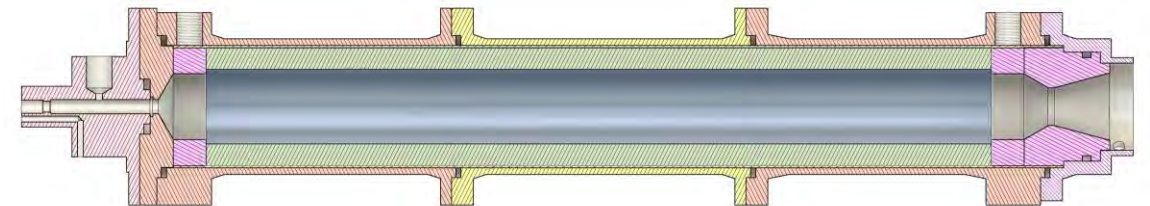
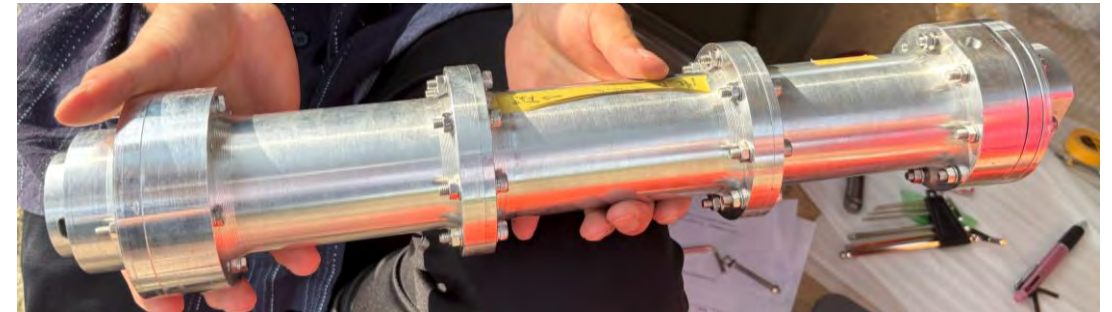

509.90 mm

# Activities of Rocket Project

Estimated reaching altitude of hybrid rocket powered by this motor : **2414 m**



Spec : Length 1953.5 mm / weigh 7.726 kg (without propulsion)

## Features of the motor

- Material
  - Engine case : Aluminum
  - Nozzle : Graphite
- Total impulse 3250 N·s
- Average impulse : 472 N
- Tank volume : 2000 cc
- Burst Pressure : 6.8 MPa (measured value)
- Maximum combustion pressure : 2.48 MPa (designed value)
- Propulsion
  - Oxidizer :  $N_2O$
  - Fuel : PMMA

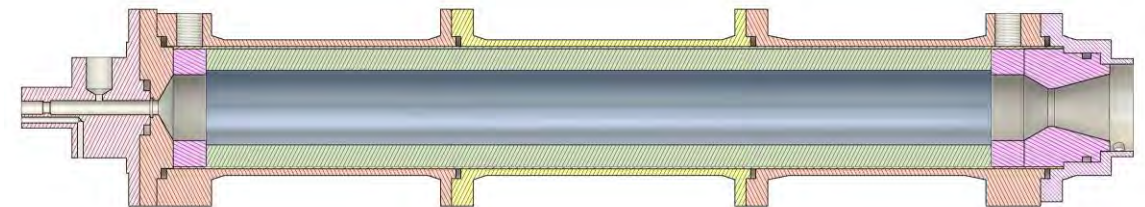

509.90 mm

# Rocket Project



TOHOKU UNIVERSITY

## Flow Rate Test

(2024/12/08 at Tohoku University)

Measure Flow Rate

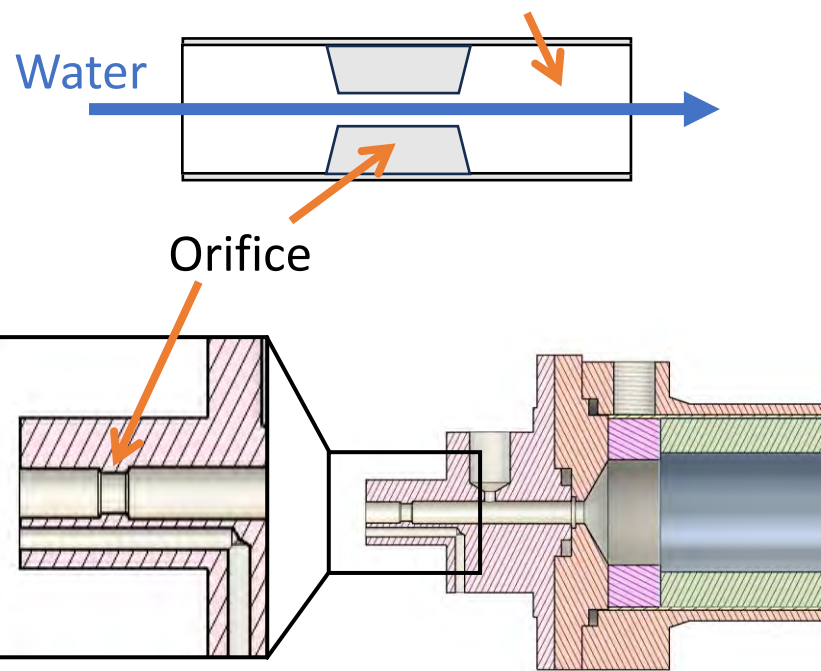

Flow coefficient : 0.66  
Diameter of orifice : 3 mm

## Proof and burst Test

(2025/5/18 at Tohoku University)

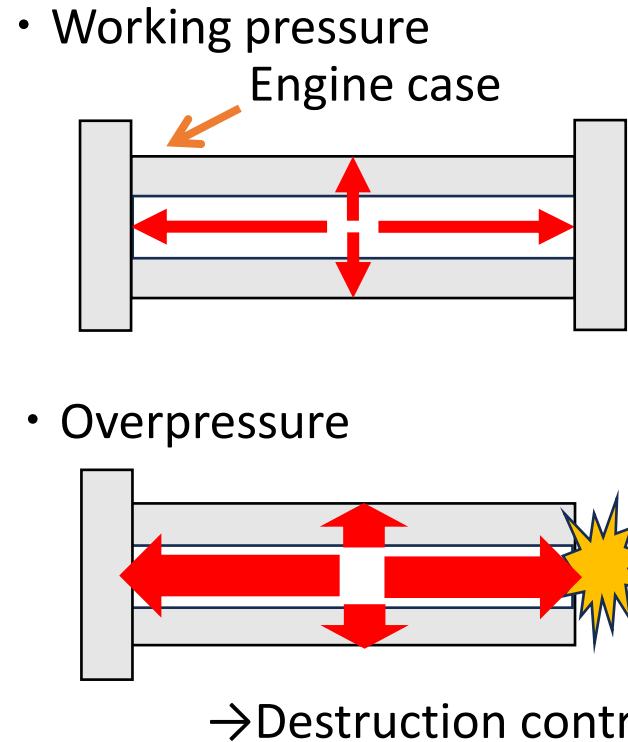

Didn't fail with 8 bolts at 10 MPa  
→ Reduce to 6 bolts and fail at 6.8 MPa

## Combustion Test

(2025/6/22 at Iwanuma, Miyagi)

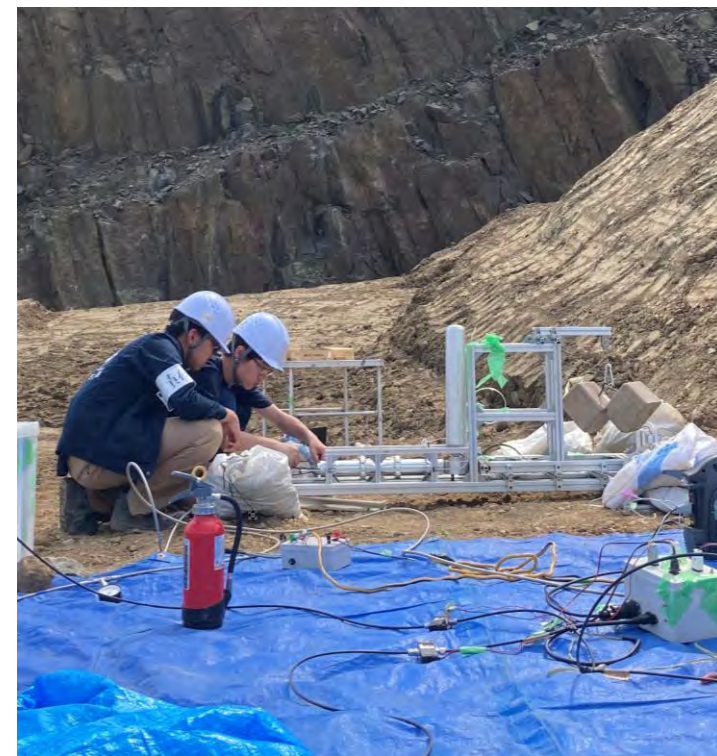

# Rocket Project

## Combustion Test



## ■ Rocket

- ✓ Improve our technology of making rockets

## ■ Hybrid rocket motor

- ✓ Continue to investigate and identify the causes of the abnormal combustion observed in the experiment
- ✓ Establish a reliable and reproducible workflow for designing, manufacturing, and evaluating our original hybrid rocket motor



# CanSat Project

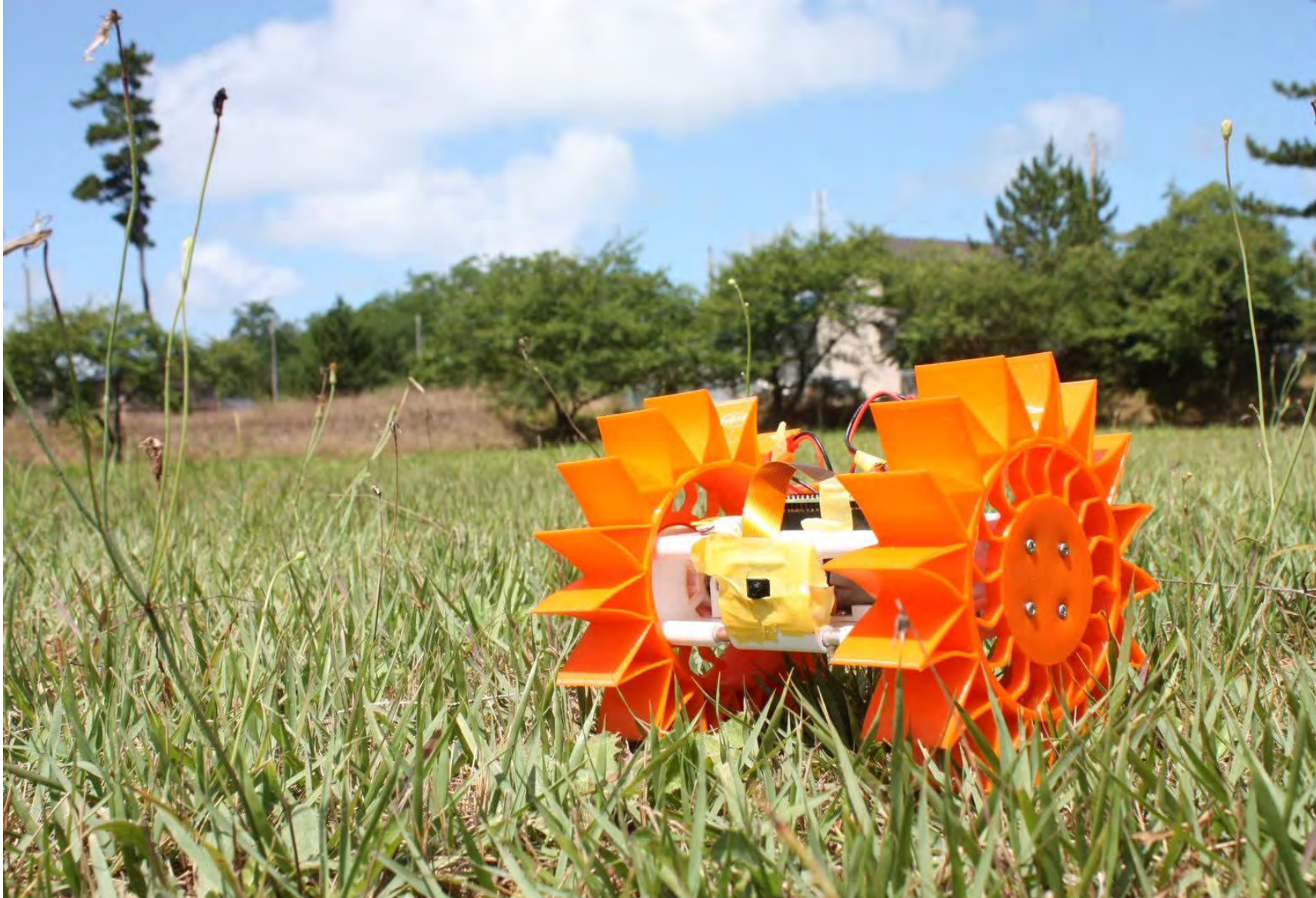

# What is CanSat

## What is CanSat

- ✓ A very small simulated satellite
- ✓ Equipped with the basic functions of a satellite or rover

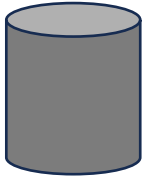

Regulation  
 $\phi$  : 146 mm, Height : 240 mm, Weight : 1050 g

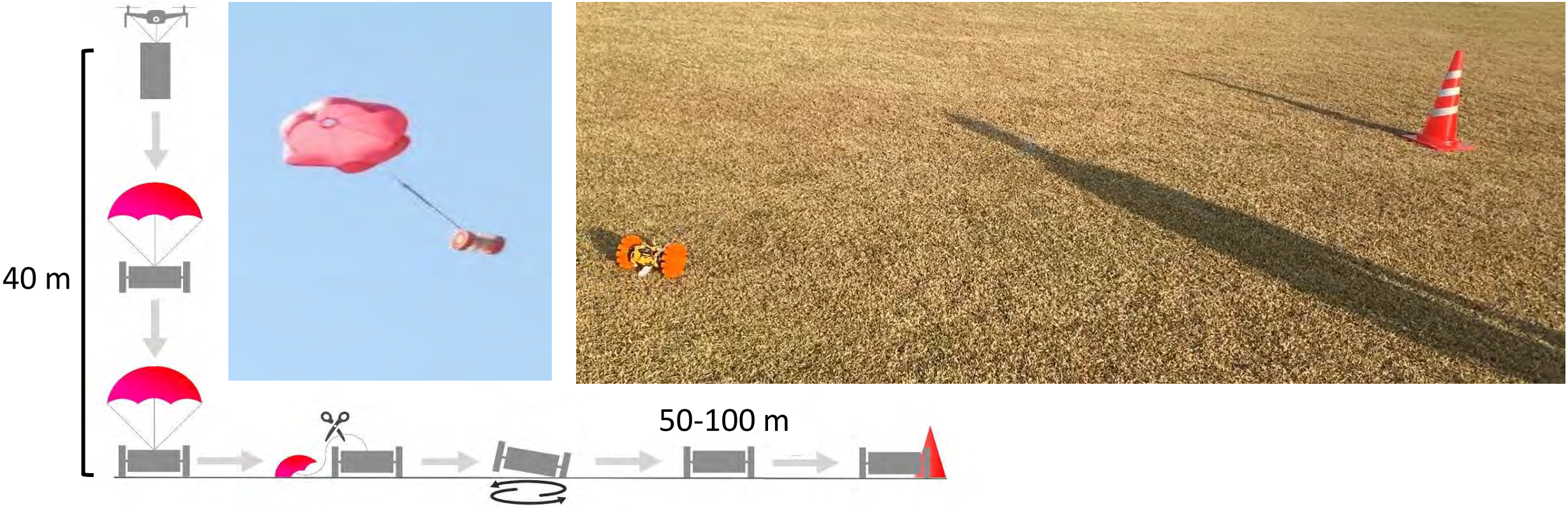

## ■ Background

Previous challenging aircrafts



## ■ Objects

Build a basic model CanSat and achieve the goal

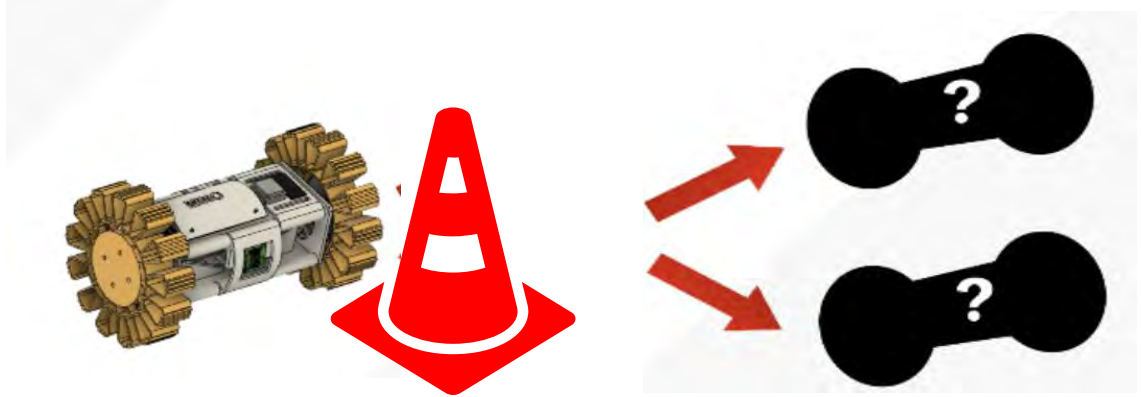

## 韋駄天 (Idaten, Speedster)

Participated in the  
Noshiro Space event

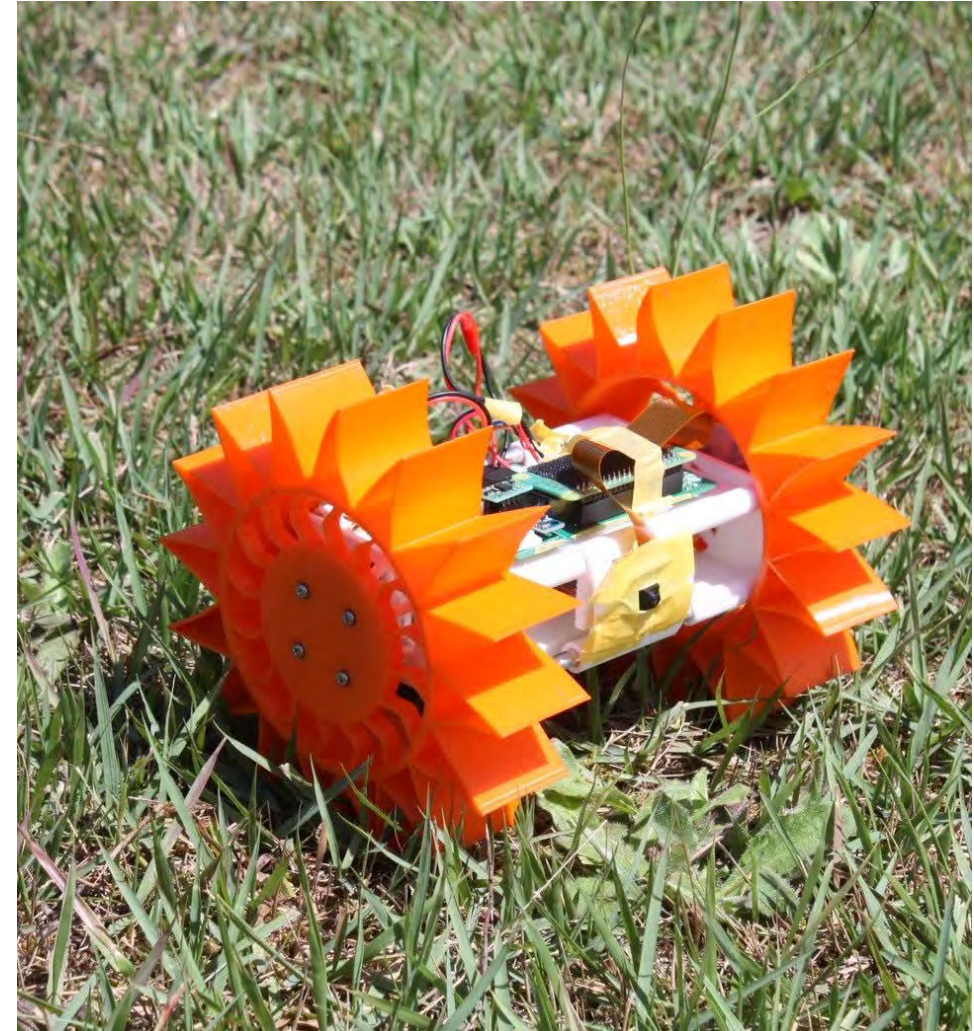
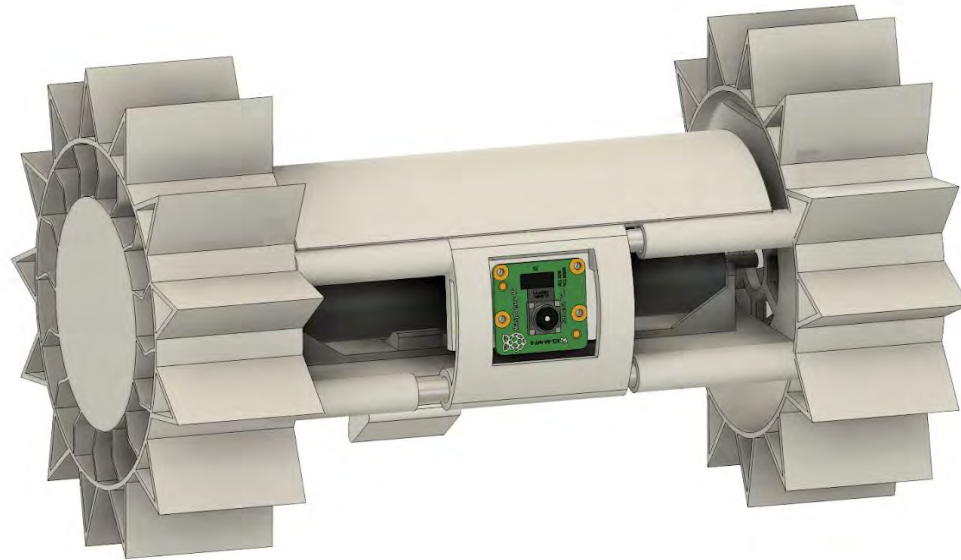

## Two key features

### ✓ Expandable tires

- Made of flexible plastic material (TPU)
- Make it easier to drive on rough terrain

### ✓ Frame structure

- Constructed with four aluminum rods
- Distributes impact from landing  
→ Protect the motor shaft and body

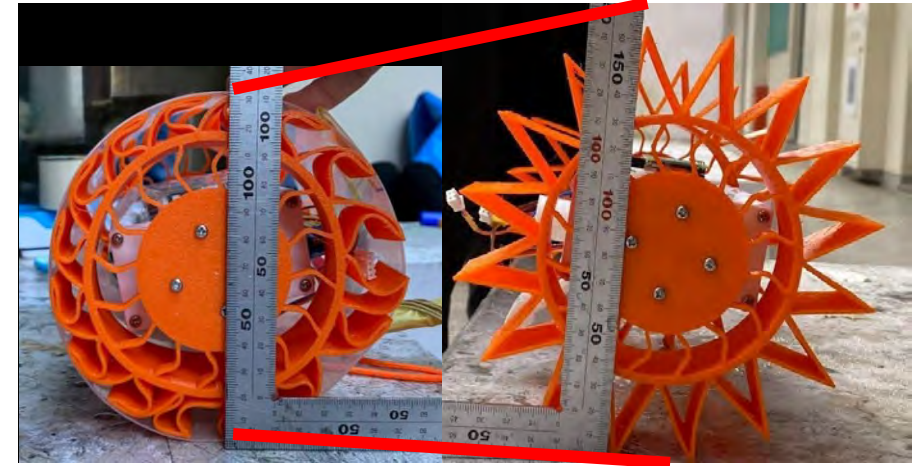

145 mm



165 mm

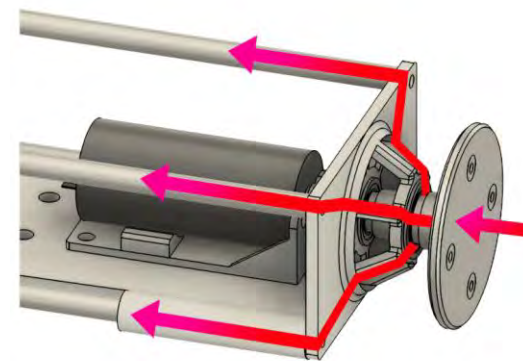

## ✓ Result

- Three successful drops without damage
- It started the race twice but got stuck on the way to the goal.
  - Next, develop bigger tire with new deployment mechanism



## ✓ Prospect

- Achieve reach the goal in the next contest
- Participate in the ARLISS competition held in USA

# Conclusion of our club activities in this year



## ■ Rocket

- ✓ Develop 3 rockets (launch one of them)
- ✓ Focus on developing our original hybrid rocket motor
- × Get normal combustion

## ■ CanSat

- ✓ Complete the basic CanSat
- × Achieve reaching a goal in competitions

## ■ What we learned this year

- ✓ Teamwork with members from different backgrounds
- ✓ Hands-on engineering through trial and error beyond classroom learning

# Acknowledgment

We extend our heartfelt gratitude for the generous support provided by the Boeing Higher Education Program.

